

Screening Instructions

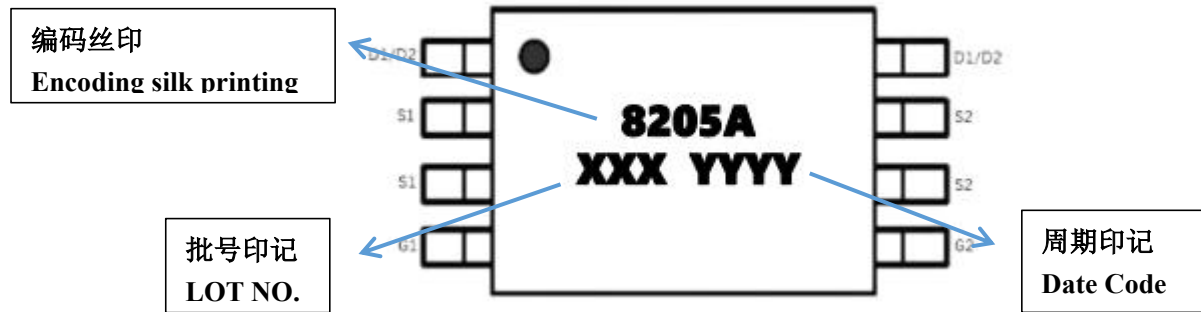

Package Mechanical Data-TSSOP-8L --- A

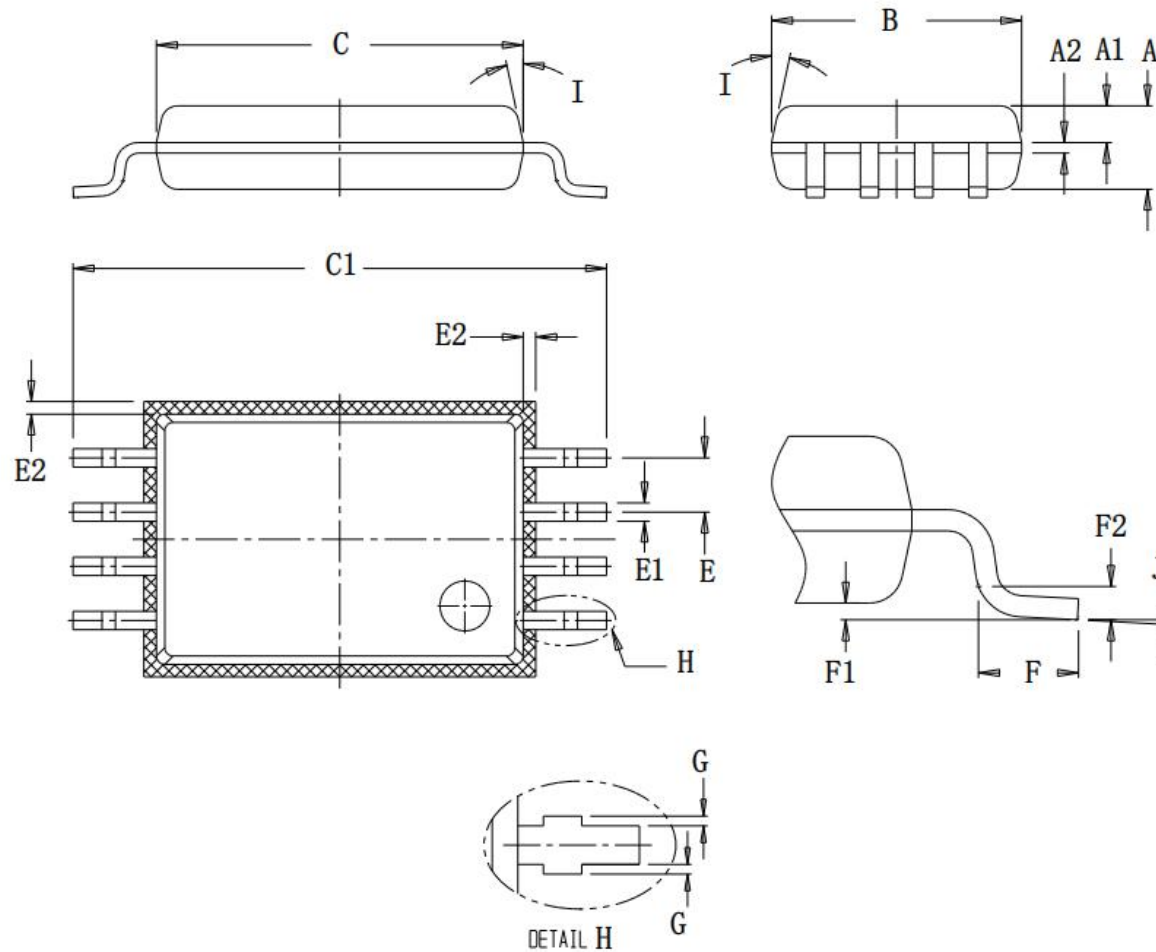

COMMON DIMENSIONS UNITS MEASURE=MILLIMETER			
SYMBOL	MIN	MID	MAX
A	0.95	1.00	1.05
A1	0.39	0.44	0.49
A2	-	0.127	-
B	2.95	3.00	3.05
C	4.35	4.40	4.45
C1	6.30	6.40	6.50
E	-	0.65 TYP	-
E1	0.195	0.22	0.245
E2	-	0.12	-
F	0.5	0.60	0.7
F1	0	0.05	0.1
F2	-	0.2	-
G	-	0.075	-
I	10°	12°	14°
J	0°	3°	6°

Reel Specification-TSSOP-8L

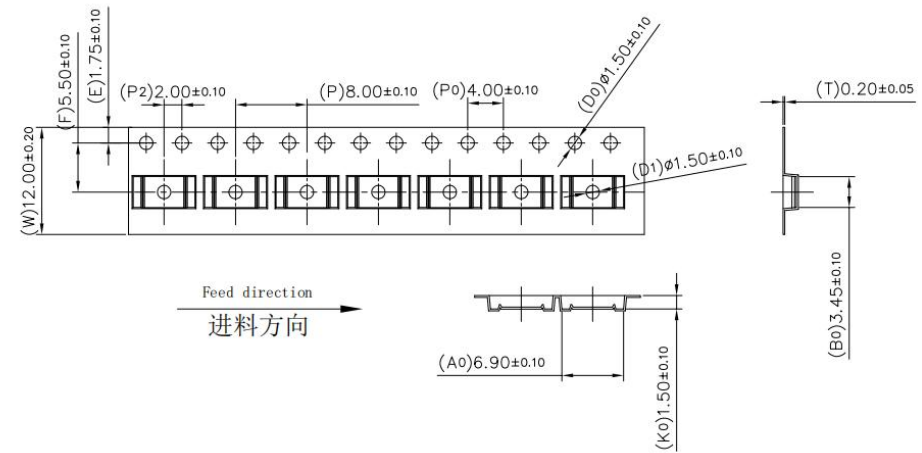
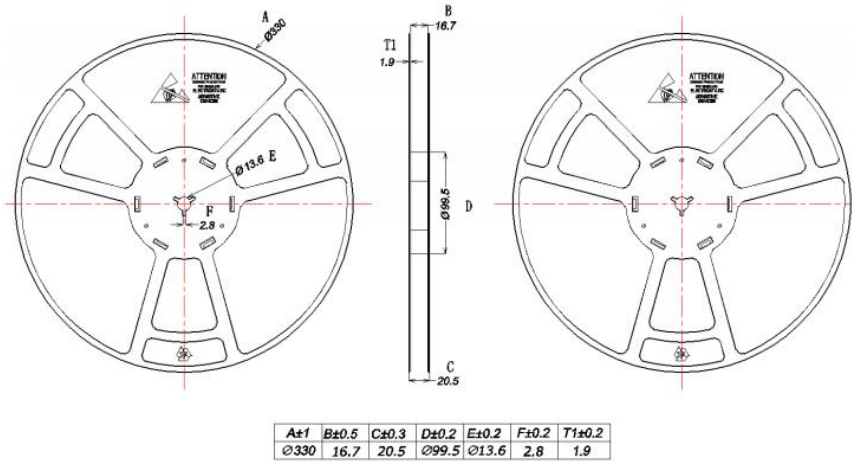

Package Quantity

封装形式 Encapsulation mode	包装方式 Modes of packing	包装数量(Package quantity)/重量 (Weight)		
TSSOP-8L	盘/Reel	5000PCS/盘 (Reel)	10000PCS/内盒 (Inner Carton)	80000PCS/箱 (Box)
		0.545KG	1.4KG	12.2KG
			362*350*50mm	380*275*370mm